

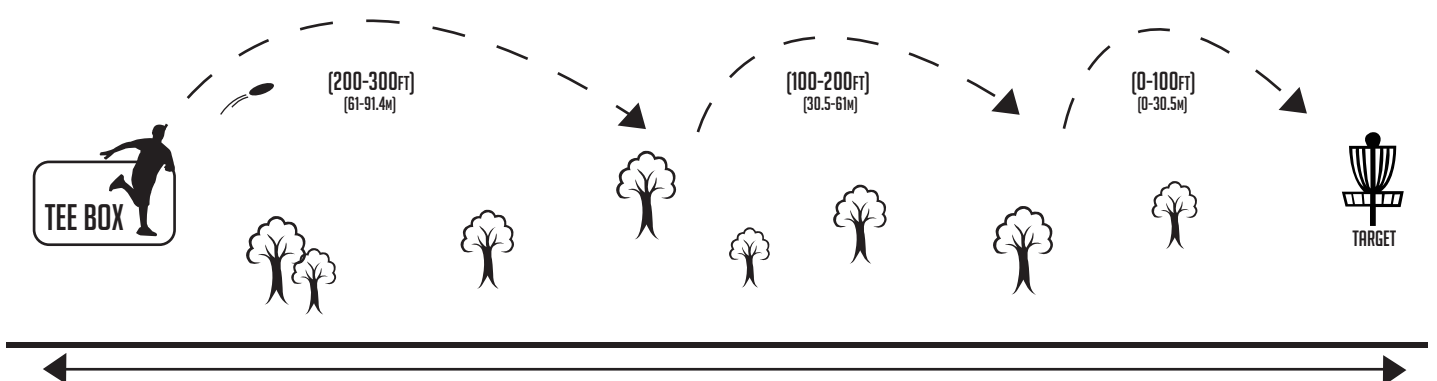

Franklin®

QUIKSET® DISC GOLF TARGET

52304

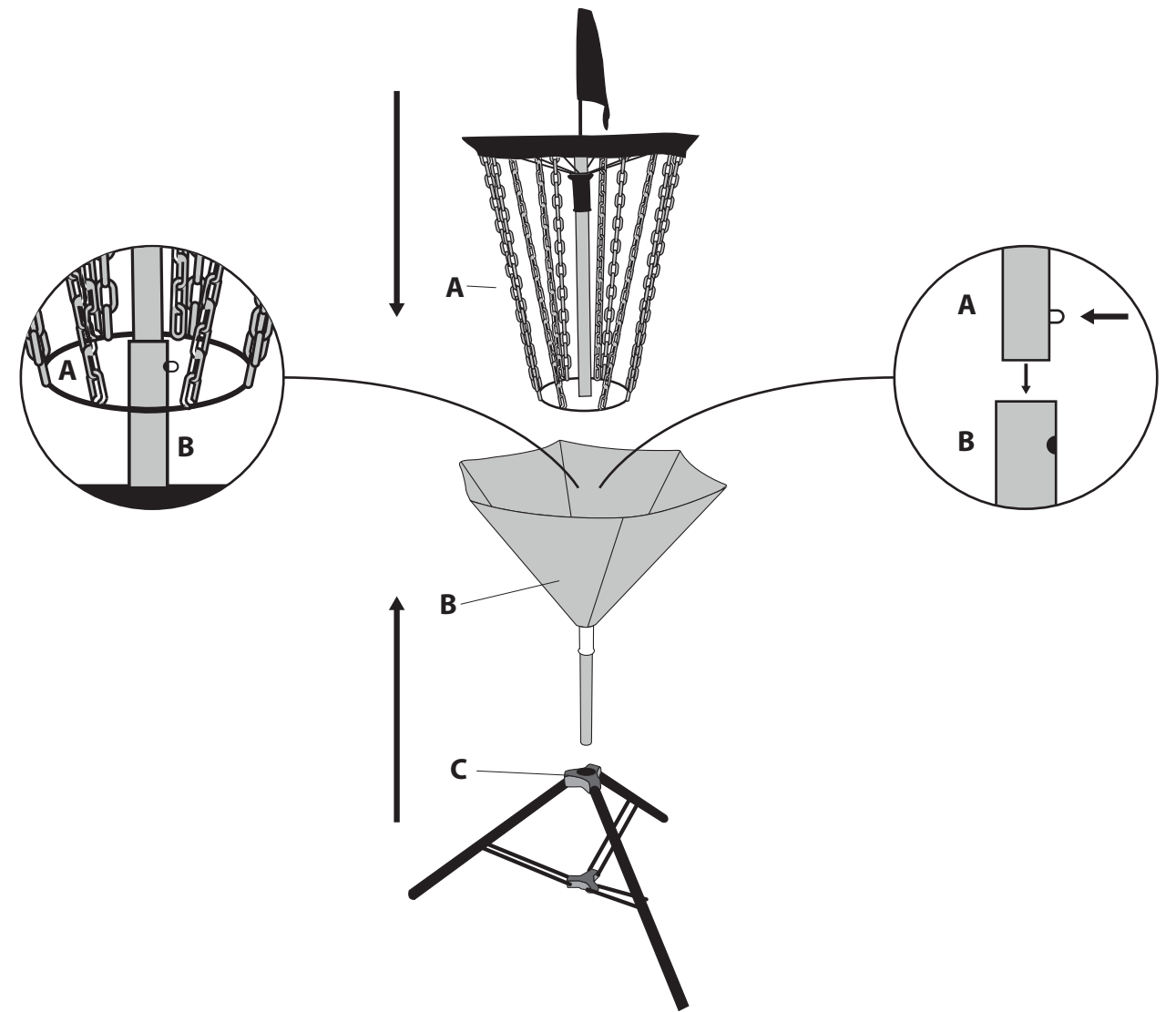
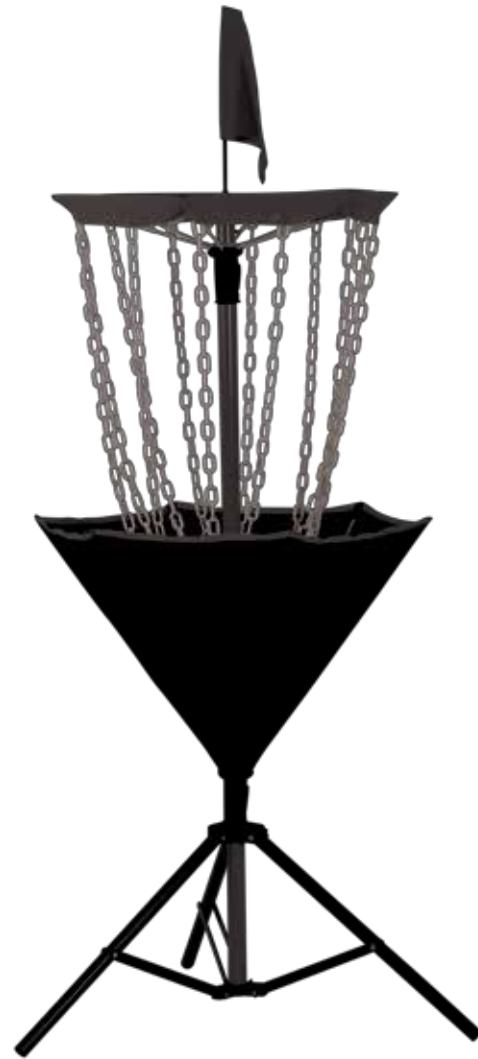

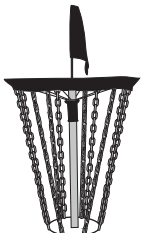
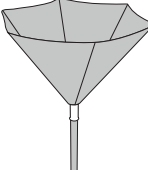
PARTS LIST

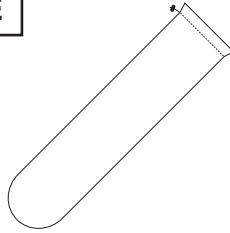
<p>A</p> 	<p>B</p> 	<p>C</p> 	<p>D</p> 	<p>E</p> 
(1) Net	(1) Umbrella base	(1) Tripod stand	(3) Discs	(1) Carry bag

- 1) DRIVE**- Play commences with a "Drive" from the Tee Box, throwing the disc as far as possible towards the Disc Golf Target.
- 2) MID-RANGE**- A player's subsequent throw often uses a more accurate "Mid-Range" style which must be thrown from the landing spot of the Drive.
- 3) PUTT**- When close enough to the target, players will choose to use the more stable toss to complete the hole.

WINNING: One should tally his/her score for the hole by the number of throws it took to get the Disc into the Target. The lowest combined score after completion of all holes is the winner!

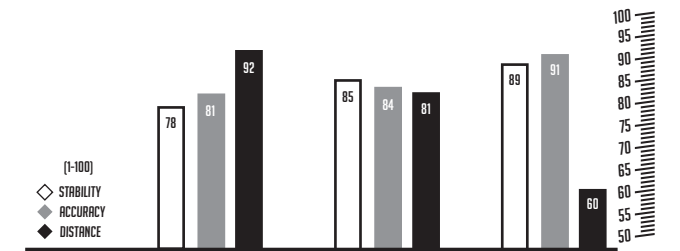

Franklin Sports Inc.
Stoughton, MA 02072
Made in China

Franklin®

For replacements parts call
1-781-341-5178 or 1-800-225-8649
OR visit www.franklinsports.com